

CTH101L SERIES MOULDED CASE CURRENT TRANSFORMERS

HOBUT

DESCRIPTION

A range of moulded case current transformers suitable for primary currents from 600 to 4000A with built in sealable terminal covers.

APPLICATION

For transforming various primary currents into 5A or 1A standard secondary using up to 100 x 55mm busbars.



FEATURES

- Built in sealable terminal covers.
- Base or busbar mounting.
- Terminals suitable for screw or push on connectors.

TECHNICAL SPECIFICATION

- Conforms to IEC185, BS 7626, BSEN 60044-1 and IEC 60044-1.
- Rated system voltage 0.72/3kV.
- Ambient temperature range -30°C to 85°C.
- Self extinguishing to UL94HB.

RANGE (Type CTH101L) 5A Secondary

VA	Class 3			Class 1			Class 0.5		
	5	10	15	5	10	15	5	10	15
600A	C1	C2	C3	C4	C5	-	C7	-	-
800A	D1	D2	D3	D4	D5	D6	D7	D8	-
1000A	E1	E2	E3	E4	E5	E6	E7	E8	E9
1200A	F1	F2	F3	F4	F5	F6	F7	F8	F9
1500A	G1	G2	G3	G4	G5	G6	G7	G8	G9
1600A	H1	H2	H3	H4	H5	H6	H7	H8	H9
2000A	-	-	J3	-	-	J6	-	-	J9
2500A	-	-	K3	-	-	K6	-	-	K9
3000A	-	-	L3	-	-	L6	-	-	L9
4000A	-	-	M3	-	-	M6	-	-	M9

1A secondary available by request.
Class 0.25 also available by request.

Order Example: A moulded case current transformer type CTH101L, with 5A secondary and 2500A primary 15VA class 1 is part number CTH101L-5-K6

DIMENSIONS (mm)

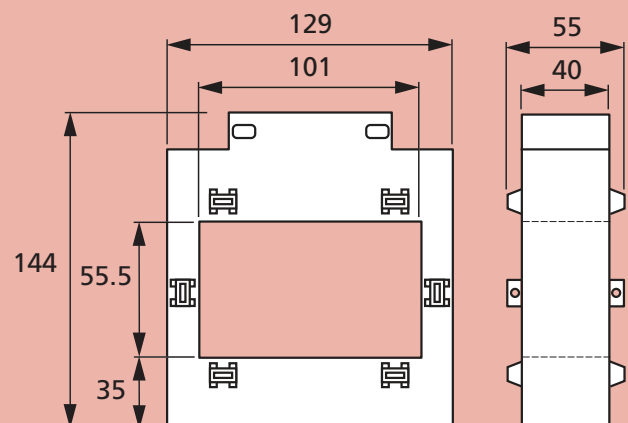

Busbar 100 x 55mm

Our policy is one of continuous development and therefore specifications may change without notice.

HOWARD BUTLER LTD

CROWN WORKS, LINCOLN ROAD
WALSALL WS1 2EB ENGLAND

Tel: 01922 640003 Fax: 01922 723626

International Tel: +44 1922 640003 E-mail: sales@hobut.co.uk

<http://www.hobut.co.uk>